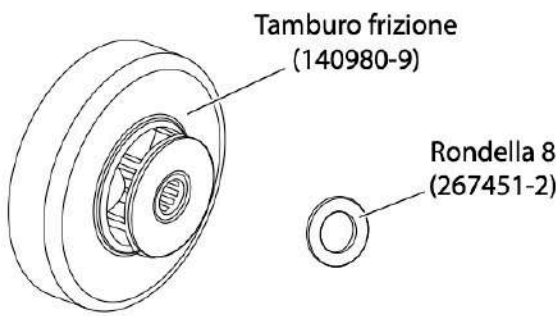
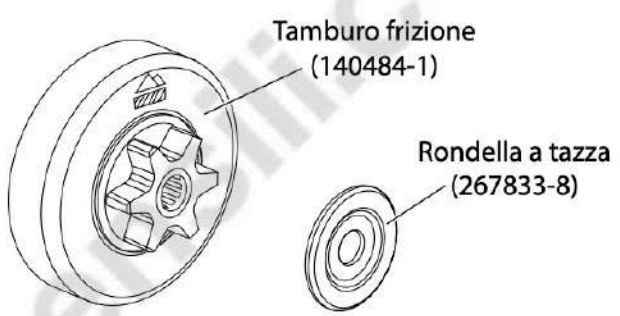

C.T.	28/2
PAG.	1/1
DATA	22/07/15

MODELLO	EA3200S, EA3201S, EA3500S, PS32C, PS32CTL, PS35C
OGGETTO	MODIFICA TAMBURO FRIZIONE E RONDELLA 8

VECCHIA PARTE	NUOVA PARTE
 <p>Tamburo frizione (140980-9)</p> <p>Rondella 8 (267451-2)</p>	 <p>Tamburo frizione (140484-1)</p> <p>Rondella a tazza (267833-8)</p>

RIF.	VECCHIA PARTE	Q.TA'	Gr. List.	I/C	NUOVA PARTE	Q.TA'	Gr. List.	NOTE
89	Tamburo frizione	1	11	No	Tamburo frizione	1	16	Sostituire come set
135	140980-9				140484-1			
32	Rondella 8	1	01	No	Rondella a tazza 8	1	01	
136	267451-2				267833-8			

I/C=INTERCAMBIABILITA'

APPROVAZIONI	
--------------	--

C.T.	32/2
PAG.	1/1
DATA	18/01/18

MODELLO	EA3200S, EA3201S, EA3500S, PS32C, PS32CTLC, PS35C
OGGETTO	MODIFICA TAMBURO FRIZIONE

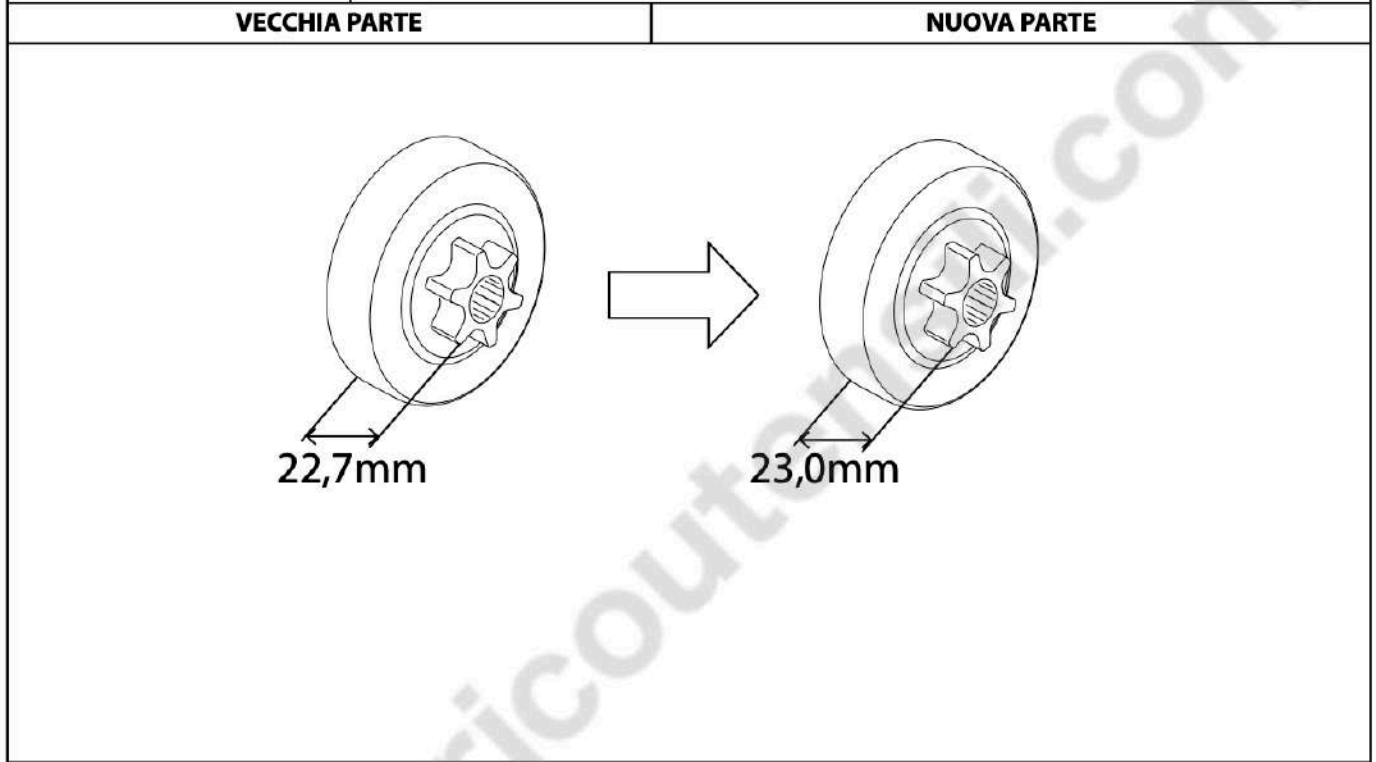

RIF.	VECCHIA PARTE	Q.TA'	Gr. List.	I/C	NUOVA PARTE	Q.TA'	Gr. List.	NOTE
89	Tamburo frizione	1	16	No	Tamburo frizione	1	16	
135	140484-1				140A30-6			

I/C=INTERCAMBIABILITA'

APPROVAZIONI		
--------------	--	--